

THIS DRAWING IS UNPUBLISHED. RELEASED FOR PUBLICATION, 19
 © COPYRIGHT 19 BY AMP INCORPORATED. ALL INTERNATIONAL RIGHTS RESERVED.

| | | | | | | | | |
|-----------|------------|---|---|-----------|-----|----------------------|--------|-------|
| LOC AF | DIST 50 | P | F | REVISIONS | | | DATE | APPD |
| | | | | ZONE | LTR | DESCRIPTION | | |
| | | | | | K | REV PER 0G1A-0145-99 | 3JUN99 | JR/JH |

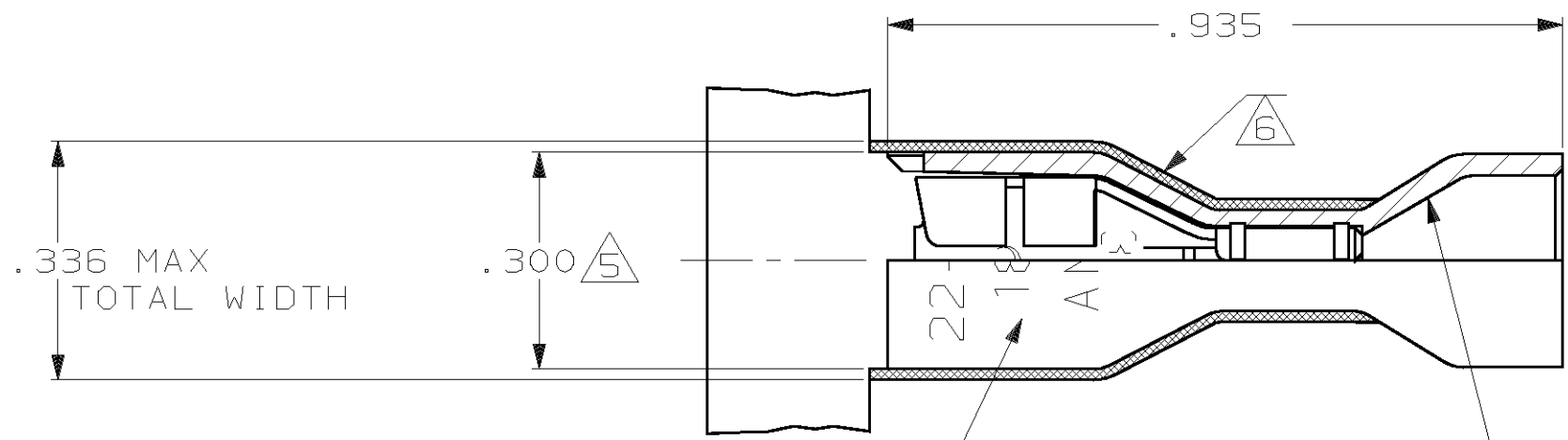

- 1 MATES WITH .032±.001×.187 TAB
- 2 WIRE STRIP LENGTH .281
- 3 INSULATION SIZE .230 MAX DIA
- 4 CONTINUOUS STRIP ON REELS
- △5 DIMENSION DOES NOT INCLUDE TRIM BURR
- △6 .015 MAX CARRIER TRIM BURR PER SIDE IS ALLOWABLE IN THE SHADED AREA

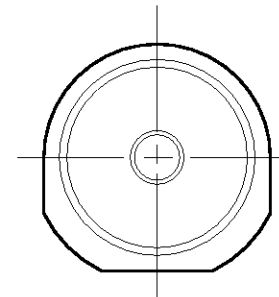
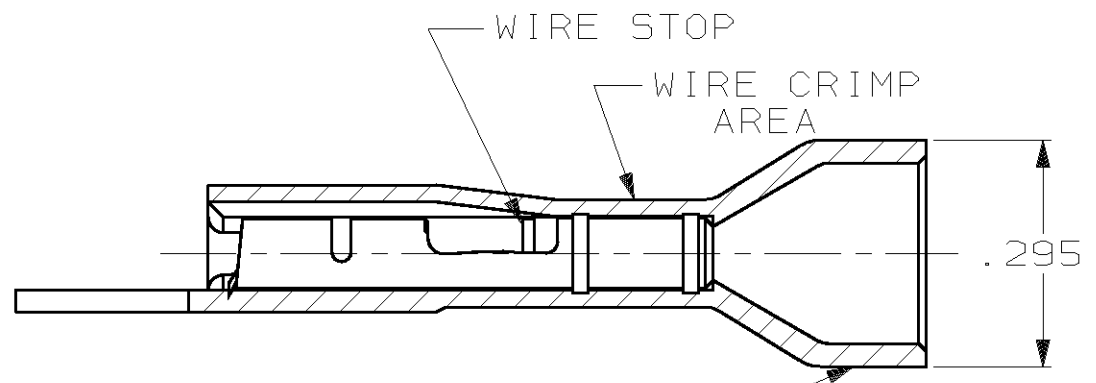
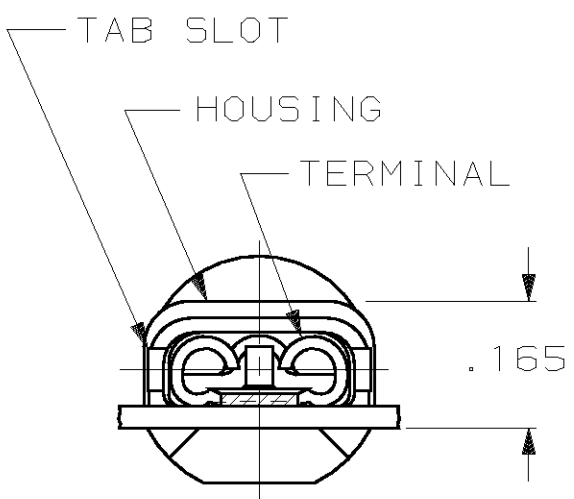

INSULATION GUIDE

WIRE AND RECEPTACLE { 22-18
 SIZE IDENTIFICATION { 187
 AMP

HOUSING: NYLON, COLOR-RED TRANSLUCENT
 RECEPTACLE: #3 HARD BRASS
 TIN PL .000080 MIN THK

2-520274-2

MATERIAL & FINISH PART NO

| | | | | |
|--|------------------------------|--|------------------|----------------------|
| DO NOT SCALE PRINT. UNLESS SPECIFIED DIMENSIONS IN INCHES TOLERANCES ON: 2 PLC DEC ± - 3 PLC DEC ± .015 ANGLES ± - | DR 11/7/88 P FORTNEY | AMP INCORPORATED Harrisburg, Pa. 17105 | | |
| | CHK 11/9/88 MS FEHER | | | |
| | APPD 11/11/88 K RANDOLPH | NAME | | |
| | APPD 11/10/88 TL SHUTTER | RECEPTACLE ASSY, ULTRA-FAST, .187 SERIES, 22-18 AWG | | |
| MATERIAL SEE TABLE | PRODUCT SPEC 108-2043 | SIZE B | FSCM NO 00779 | DRAWING NO 520274 |
| FINISH SEE TABLE | APPLICATION SPEC 114-2123 | SCALE 4:1 | SHEET 1 OF 1 | |
| | WEIGHT - | | | |